

Barwood
Products Ltd

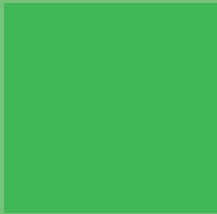

Supporting people
with special needs

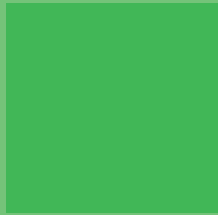
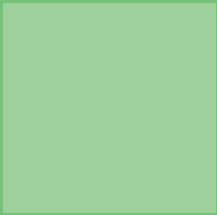

TRADE PRICE LIST

Document M 2004 Toilet Packs

Products featured on these 2 pages have been selected to meet the requirements of **Document M** of the Building Regulations, effective May 2004.



Low Level Pack

High Pan, Cistern with Fittings & Spatula Lever, Basin, Spraymixer Tap, Seat, Bottle Trap, Waste, 5 x 600mm Grab Rails, 1 x 890mm Hinged Support Rail, 1 x Back Rest Pad

BDM315K/04/PCW

Part No.	Description	List Price
BDM315K/04/PCW	With White Rails and White Seat	£615.44
BDM315K/04/5011/PCC	With Blue Rails and Blue Seat	£633.53



Close Coupled Pack

High Pan, Cistern with Fittings - Spatula Lever/Push Button, Basin, Spraymixer Tap, Seat, Bottle Trap, Waste, 5 x 600mm Grab Rails, 1 x 890mm Hinged Support Rail

BDM700K/04/5011/PCC

BDM700K/04/PCW	With White Rails and White Seat Lever Cistern	£678.36
BDM700K/04/5011/PCC	With Blue Rails and Blue Seat Lever Cistern	£696.44
BDM750K/04/PCW	With White Rails and White Seat Push Button Cistern	£678.36
BDM750K/04/5011/PCC	With Blue Rails and Blue Seat Push Button Cistern	£696.44



Back to Wall Pack

High Pan, Cistern with Fittings & Spatula Lever, Basin, Spraymixer Tap, Seat, Bottle Trap, Waste, 5 x 600mm Grab Rails, 1 x 890mm Hinged Support Rail, 1 x Back Rest Pad, Back Box

BDM800K/04/5011/PCC

BDM800K/04/PCW	With White Rails and White Seat Exposed Cistern - Lever	£852.79
BDM800K/04/5011/PCC	With Blue Rails and Blue Seat Exposed Cistern - Lever	£874.12
BDM820K/04/PCW	With White Rails and White Seat Concealed Cistern - Lever	£852.79
BDM820K/04/5011/PCC	With Blue Rails and Blue Seat Concealed Cistern - Lever	£874.12



Wall Hung Pack

Wall Hung Pan, Ducted Cistern with Fittings & Spatula Lever, Basin, Spraymixer Tap, Seat, Bottle Trap, Waste, 5 x 600mm Grab Rails, 1 x 760mm Hinged Support Rail.

BDM850K/04/PCW

BDM850K/04/PCW	With White Rails and White Seat Concealed Cistern - Lever	£907.36
BDM850K/04/5011/PCC	With Blue Rails and Blue Seat Concealed Cistern - Lever	£930.04



SANICOMPACT

Document M Packs - With Saniflo Systems

SANICOMPACT	Pan with Integral Push Button Macerator	£1,331.08
SANICOMPACT	Full set of White Rails Pan with Integral Push Button Macerator	£1,344.40
SANIBEST	Full set of Blue Rails Low Level Pack inc. Sanibest unit.	£1,535.64
SANIBEST	White Rails and Seat Low Level Pack inc. Sanibest unit.	£1,551.03
SANIBEST	Blue Rails and Seat Close Coupled Pack inc. Sanibest unit.	£1,598.56
SANIBEST	White Rails and Seat Close Coupled Pack inc. Sanibest unit.	£1,615.52
SANIBEST	Blue Rails and Seat	

**PLEASE NOTE:
ALL PRICES EXCLUDE VAT**

**All packs are available with In Line Thermostatic Mixing Valves
To order add 'TMV' to the Part Number and £81.81 to the List Price.**

Document M 2004 Upgrades & Separates

Existing facilities can be modified to comply with the design considerations identified within the **Document M**. The following products have been developed satisfy the latest requirements.

Rail Kits

Part No.	Description	List Price
BDM315/04/PCW	Low Level Kit comprising 5 x 600mm Grab Rails, 1 x 890mm Hinged Support Rail, 1 x Back Rest Pad – White Rails	£152.60
BDM315/04/5011/PCC	Low Level Kit comprising 5 x 600mm Grab Rails, 1 x 890mm Hinged Support Rail, 1 x Back Rest Pad – Blue Rails	£183.61
BDM700/04/PCW	Close Coupled Kit comprising 5 x 600mm Grab Rails, 1 x 890mm Hinged Support Rail – White Rails	£122.06
BDM700/04/5011/PCC	Close Coupled Kit comprising 5 x 600mm Grab Rails, 1 x 890mm Hinged Support Rail – Blue Rails	£148.41

BDM315



Support Rails

B305/04/PCW	Hinged Support Rail – 890mm projection – White	£65.50
B305/04/PCC/5011	Hinged Support Rail – 890mm projection – Blue	£73.75
BFW308/04/PCW	Floor to Wall Rail – 890mm proj. x 680mm high – White	£27.26
BFW308/04/PCC/5011	Floor to Wall Rail – 890mm proj. x 680mm high – Blue	£29.97
B316/PCW	Back Rest Rail – White	£19.52
B316/PCC/5011	Back Rest Rail – Blue	£22.44
B317/PCW	Back Rest Rail & Pad – White	£30.54
B317/PCC/5011	Back Rest Rail & Pad – Blue	£34.06

B305



B317

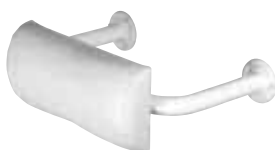

Special Rails

BG1750/04/S/PCW	Bath Rail – 1750mm x 35mm – Straight – White	£50.70
BG1750/04/S/PCC/5011	Bath Rail – 1750mm x 35mm – Straight – Blue	£55.76
BG1750/04/CR/PCW	Bath Rail – 1750mm x 35mm – Cranked – White	£58.31
BG1750/04/CR/PCC/5011	Bath Rail – 1750mm x 35mm – Cranked – Blue	£64.13

RAN1



Separates

RAN1	Rangemoor Single Ring Seat – c/w Stainless Steel Hinges – White – Blue	£44.70 £46.85
RAN2	Rangemoor Seat and Cover – c/w Stainless Steel Hinges – White – Blue (Not to be used on Doc M installations)	£56.34 £59.25

BPLBOX



BPLMON



B202



BPLLEV	Spatula Lever	£10.15
BPLLEV/EXT	Spatula Lever for 12" duct	£32.30
BPLBOX	Back Box for Back To Wall Pan	£92.38
BPLMON	Spray Mixer Tap	£70.64
BPLTMV	In Line Thermostatic Valve	£81.81
B202	Baby Changing Unit – Hinged with Form Retentive Fabric Covering 1025mm x 545mm	£207.65

Hinged Shower Seats

With Fabric Cover

Part No.	Description	PCW	NC PCC	SSW	PSS SSS
B215	Hinged Shower Seat, Fabric Covered, with Back and Folding Arms Size 455 x 465mm Upright Projection 135mm	£163.81	£175.35	£176.11	£189.31
B216	Hinged Shower Seat, Fabric Covered, with Back, Folding Arms and Leg Size 455 x 465mm Upright Projection 135mm	£207.65	£219.18	£216.42	£232.66
B216F	Hinged Shower Seat, Fabric Covered, with Back, Folding Arms, and Leg with Adjustable Feet Size 455 x 465mm Upright Projection 135mm	£219.63	£231.17	£227.44	£244.50

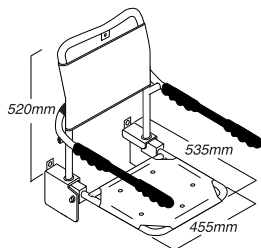

B215

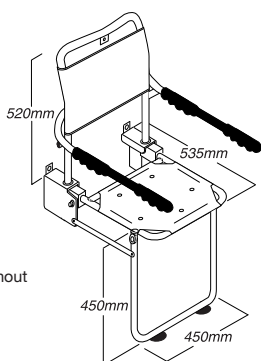

B216F

B216
As B216F but without Adjustable Feet

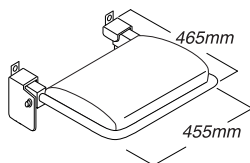

B206

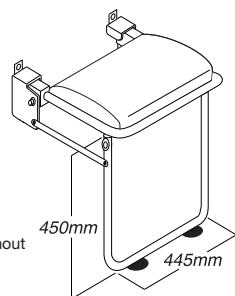

B211F

B211
As B211F but without Adjustable Feet

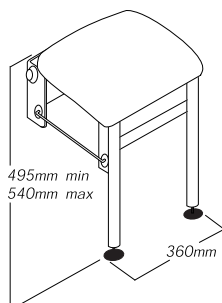

B214

With Cushioned Seat

Part No.	Description	PCW	NC PCC	SSW	PSS SSS
B206	Hinged Cushioned Shower Seat Size 455 x 465mm Upright Projection 135mm	£73.79	£78.40	£93.32	£100.32
B211	Hinged Cushioned Shower Seat, with Folding Leg Size 455 x 465mm Upright Projection 135mm	£117.62	£122.24	£133.63	£143.65
B211F	Hinged Cushioned Shower Seat, with Folding Leg and Adjustable Feet Size 455 x 465mm Upright Projection 135mm	£129.81	£134.22	£144.65	£155.50
B214	Hinged Cushioned Shower Seat, with Adjustable Leg Size 455 x 465mm Height 495mm – 540mm max Upright Projection 135mm	£86.87	N/A	N/A	N/A

Hinged Shower Seats

With Removable Cover

Part No.	Description	PCW	NC PCC	CP	SSW	PSS SSS
B217	Hinged Shower Seat with Removable Cover Size 400 x 450mm Upright Projection 115mm	£118.27	POA	POA	£140.04	£150.54
B217F	Hinged Shower Seat with Removable Cover and Folding Leg Size 400 x 450mm Upright Projection 135mm	£162.11	POA	POA	£180.35	£193.88

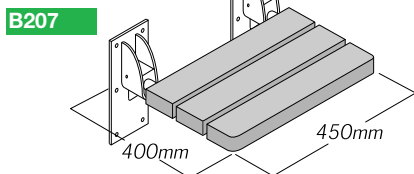

With Beechwood Slats

B207	Hinged Shower Seat with Beechwood Slats Size 400 x 450mm Upright Projection 115mm	£73.79	£76.66	£82.14	£105.13	£113.02
B208	Hinged Shower Seat with Beechwood Slats and Folding Leg Size 400 x 450mm Upright Projection 135mm	£117.62	£120.50	£125.98	£145.45	£156.35

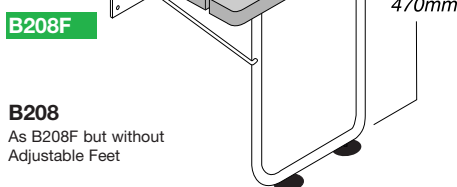

B208
As B208F but without Adjustable Feet

B208F	Hinged Shower Seat with Beechwood Slats and Folding Leg with Adjustable Feet. Size 400 x 450mm Upright Projection 135mm	£129.61	£132.48	£126.19	£156.47	£168.20
--------------	--	---------	---------	---------	---------	---------

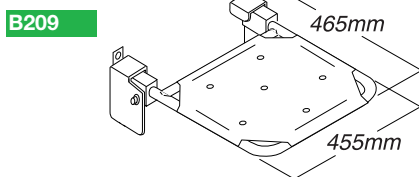

With Fabric Cover

B209	Hinged Shower Seat – Fabric Covered Size 465 x 455mm Upright Projection 115mm	£117.67	£141.20	POA	£140.04	£150.54
B212	Hinged Shower Seat – Fabric Covered, with Folding Leg Size 465 x 455mm Upright Projection 135mm	£162.11	£185.04	POA	£180.35	£193.88

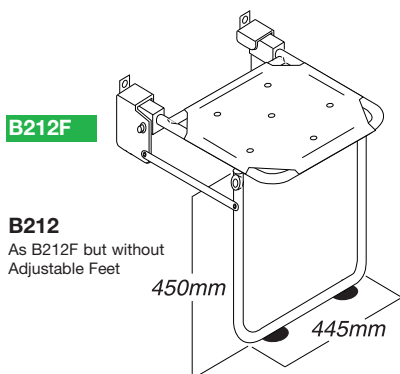

B212
As B212F but without Adjustable Feet

B212F	Hinged Shower Seat – Fabric Covered, and Folding Leg with Adjustable Feet. Size 465 x 455mm Upright Projection 135mm	£174.09	£197.02	POA	£191.37	£205.73
--------------	---	---------	---------	-----	---------	---------

Hinged Support Rails

Double Arms

Part No.	Description	PCW	NC PCC	CP	PVCR	SSW	PSS SSS
B305	Hinged Support Rail 765mm Projection x 28mm dia. Note: Detachable Toilet Roll Holder B578 (see Page 11) is available for use with this product.	£55.55	£63.81	£78.34	POA	£78.51	£86.36
B305/04	Hinged Support Rail 890mm Projection	£65.50	£73.75				
B301	Hinged Support Rail 760mm Projection x 32mm dia. Note: Detachable Toilet Roll Holder B577 (see Page 11) is available for use with this product.	£59.34	£68.14	£83.66	POA	£83.84	£92.54
B303	Hinged Support Rail with folding leg 765mm Projection x 28mm dia.	£89.35	£100.78	£110.54	POA	£111.73	£121.72
B303/04	Hinged Support Rail 890mm Projection	£105.39	£118.66				

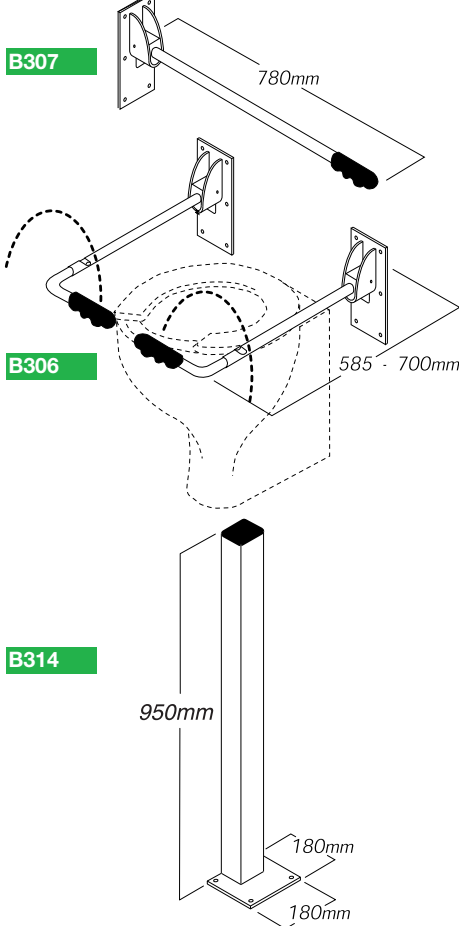

Single Arms

Part No.	Description	PCW	NC PCC	CP	PVCR	SSW	PSS SSS
B307	Hinged Foldaway Single Support Rail 780mm Projection x 28mm dia	£45.27	£52.05	£58.83	£66.91	£61.53	£67.68
B306	Hinged Gated Foldaway Support Rail Adjustable between 585mm to 700mm Projection x 28mm dia						
	Each	£68.95	£78.80	N/A	N/A	N/A	N/A
	Pair	£124.11	£140.50	N/A	N/A	N/A	N/A

Note: On all Polished and Satin Stainless Steel Hinged Arms the Aluminium Back Plate and Block is White Powder Coated

B314	Floor Mounted Column For use with Hinged Support Rails/Shower Seats 950mm High x 180mm sq. base Supplied with 3 'U' Bolts and Locking Nuts	£65.72	£75.59	N/A	N/A	N/A	N/A
-------------	--	--------	--------	-----	-----	-----	-----

Grab Rails – Straight

Grab Rails – Straight

Part No.	Description	PCW	NC PCC	CP	PVCR	SSW	PSS SSS
25mm Diameter							
BG1225	Grab Rail 300mm Long	£6.20	£6.82	£7.84	£10.12	£12.14	£13.36
BG1525	Grab Rail 380mm Long	£7.10	£7.82	£8.52	£11.61	£12.30	£13.53
BG1825	Grab Rail 450mm Long	£7.39	£8.13	£8.89	£12.07	£12.42	£13.66
BG2425	Grab Rail 600mm Long	£7.64	£8.39	£10.79	£12.47	£12.97	£14.27
BG3025	Grab Rail 750mm Long	£8.96	£9.86	£11.95	£14.65	£13.73	£15.11
BG3625	Grab Rail 900mm Long	£10.07	£11.07	£13.37	£16.44	£14.22	£15.65

32mm Diameter

BG1232	Grab Rail 300mm Long	£9.48	£10.42	£12.00	£15.47		
BG1532	Grab Rail 380mm Long	£9.84	£10.82	£12.45	£16.06		
BG1832	Grab Rail 450mm Long	£10.32	£11.33	£12.59	£16.63		
BG2432	Grab Rail 600mm Long	£10.90	£12.00	£13.87	£17.94		
BG3032	Grab Rail 750mm Long	£12.13	£13.33	£14.50	£19.79		
BG3632	Grab Rail 900mm Long	£12.60	£13.85	£19.88	£20.59		
BG4832	Grab Rail 1200mm Long	£14.29	£16.09	£22.60	£39.22		

35mm Diameter

BG1235	Grab Rail 300mm Long	£9.82	£10.80	£12.01	£16.03	£14.75	£16.22
BG1535	Grab Rail 380mm Long	£10.20	£11.21	£12.47	£16.65	£15.32	£16.84
BG1835	Grab Rail 450mm Long	£10.68	£11.75	£12.91	£17.45	£16.04	£17.63
BG2435	Grab Rail 600mm Long	£11.31	£12.44	£14.47	£18.49	£16.76	£18.44
BG3035	Grab Rail 750mm Long	£12.91	£14.19	£15.59	£21.09	£17.54	£19.29
BG3635	Grab Rail 900mm Long	£13.41	£14.74	£16.70	£30.40	£31.83	£35.01
BG4835	Grab Rail 1200mm Long	£15.50	£17.05	£17.99	£39.22	£41.38	£45.51

Grab Rails – Plastic Flanges 35mm Diameter

Rails are Powder Coated Mild/Stainless Steel, with Plastic Flanges and Flange Covers which allow for fitting without earth bonding.

		PCW	SS
BPF2435C/PCW	Grab Rail 600mm Long – White	£15.04	£22.56
BPF2435C/PCC/5011	Grab Rail 600mm Long – Blue	£16.54	£24.81
BPF2435C/PCC/3003	Grab Rail 600mm Long – Red	£16.54	£24.81
BPF2435C/PCC/1003	Grab Rail 600mm Long – Yellow	£16.54	£24.81

Finish Codes

PCW	Powder Coated White
NC	Nylon Coated White
PCC	Powder Colour Coated
CP	Chrome Plate
PVCR	PVC Ribbed
PSS	Polished Stainless Steel
SSS	Satin Stainless Steel
SSW	Stainless Steel White

Specials

Products can be produced to suit specific requirements. Full dimensional information and RAL codes, when applicable, must be provided.

Colour Surcharges

A surcharge of £35 will be incurred on small quantities of product required in Special Colours to cover the minimum batch charge from pigment suppliers.

Grab Rails – Special Purpose

Extra Long Rails 35mm Diameter

BG333

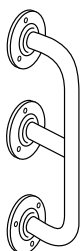

Part No.	Description	PCW	NC PCC	CP	PVCR	SSW	PSS SSS
BG333	Straight Grab Rail 3 point fixing.						
	1200mm Long	£40.84	£44.92	POA	POA	£46.68	£51.35
	1500mm Long	£46.73	£51.40	POA	POA	£53.05	£58.35
	1800mm Long	£50.70	£55.76	POA	POA	£60.47	£66.52
State size when ordering - Other sizes available to order							

BG304

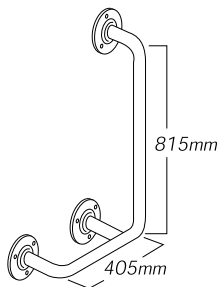

Shower/Bath

Part No.	Description	PCW	NC PCC	CP	PVCR	SSW	PSS SSS
BG304	Shower/Bath Rail 3 point fixing Handed - State hand when ordering	£33.32	£38.32	POA	£39.22	POA	POA
405mm x 815mm							

BG310

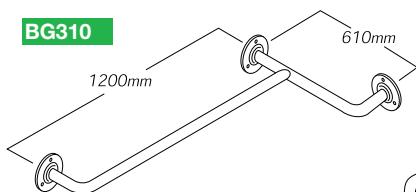

BG310	Over Bath Support Rail 3 point fixing	£33.32	£36.65	POA	£43.14	£39.68	£43.50
1200mm x 610mm							

BG319

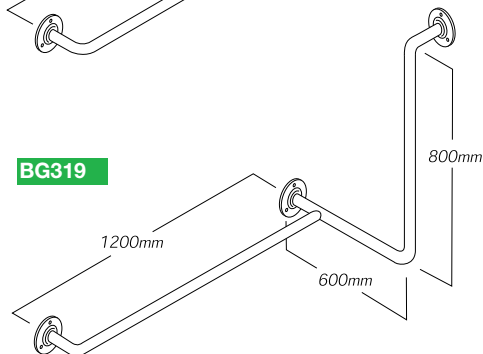

Over Bath

Part No.	Description	PCW	NC PCC	CP	PVCR	SSW	PSS SSS
BG319	Over Bath Support Rail with Vertical arm 3 point fixing.	£73.79	£76.66	POA	£83.06	£74.26	£76.38
Handed - State hand when ordering							
1200mm x 600mm x 800mm							

BG120

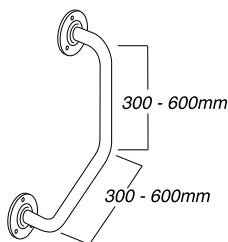

Grab Rails – Cranked 35mm Diameter

Part No.	Description	PCW	NC PCC	CP	PVCR	SSW	PSS SSS
BG120	Cranked Grab Rail 120°						
	300mm x 300mm	£16.73	£18.92	£20.53	£20.76	£19.20	£20.36
	375mm x 375mm	£17.30	£19.03	£22.49	£24.23	£22.38	£23.55
	450mm x 450mm	£18.11	£19.91	£23.37	£25.38	£23.44	£24.61
	600mm x 600mm	£20.59	£22.64	£27.10	£28.84	£26.63	£27.79
State size when ordering							

BG900

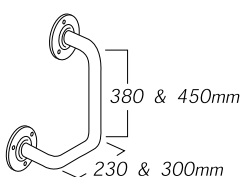

BG900	Cranked Grab Rail 90° – Handed						
	380mm x 250mm	£16.72	£20.53	£21.38	£20.88	£19.20	£20.36
	450mm x 300mm	£17.30	£19.03	£22.49	£24.23	£22.38	£23.55
State hand and size when ordering							

Note: Snap on Metal Flanges available on all Grab Rails to conceal fixings at an additional cost of £5.88 per rail. To order add 'C' to Part No. e.g. BG1225C.

Grab Rails – Special Purpose

Floor to Ceiling 35mm Diameter

Part No.	Description	PCW	NC PCC	CP	PVCR	SSW	PSS SSS
BV311	Floor to Ceiling Pole – with Loose Flange to adjust height 2750mm long	£32.65	£35.91	N/A	£35.49	£39.78	£41.89
BV312	Floor to Ceiling Pole – with Loose Flange to adjust height, and Side Support Stay 2750mm long	£39.37	£43.31	N/A	£40.38	£43.62	£44.56

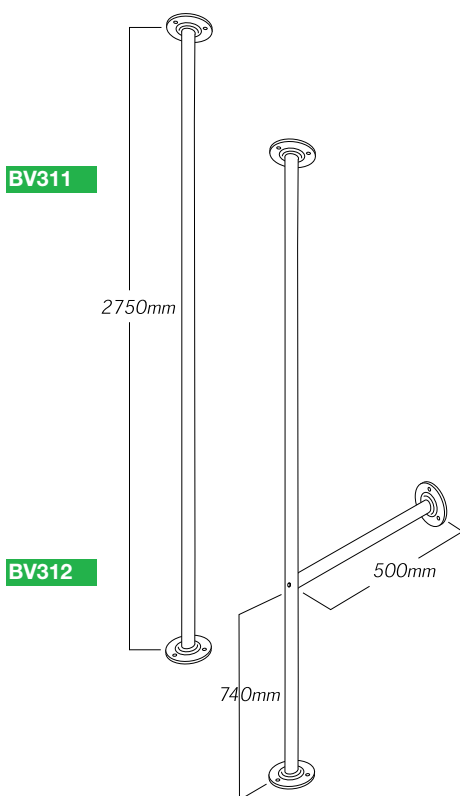

Floor to Wall 35mm Diameter

Part No.	Description	PCW	NC PCC	CP	PVCR	SSW	PSS SSS
BFW308	Floor to Wall Support Rail 740mm x 700mm	£21.81	£23.98	POA	£36.80	£33.85	£35.97
BFW309	Floor to Wall Support Rail with Stay 3 point fixing 740mm x 700mm	£24.23	£26.64	POA	£38.07	£35.01	£37.13
BFW308/04	Floor to Wall Support 680mm x 890mm	£27.26	£29.97	POA	£42.83	£39.39	£41.77
BFW313	Floor to Wall Support Rail – with Side Leg 3 point fixing. 740mm x 700mm 200mm x 300mm	£28.03	£30.83	POA	£42.68	£39.25	£41.38

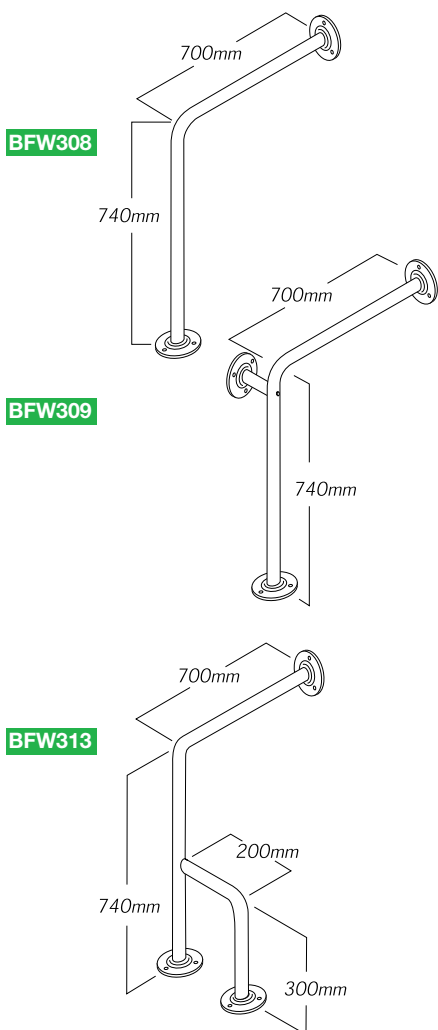

Note: Snap on Metal Flanges available on all Grab Rails to conceal fixings at an additional cost of £5.88 per rail. To order add 'C' to Part No. e.g. BG1225C.

Plastic Grab Rails

Interior Use Luxury Range

Part No.	Description	White – No Covers	White – With Covers	Colours – With Covers
BPG8274	Plastic Grab Rail – Straight	£9.30	£10.54	£15.86
BPG8276	Plastic Grab Rail – Straight Dia. 35mm x 450mm Long	£10.85	£12.29	£17.38
BPG8278	Plastic Grab Rail – Straight Dia. 35mm x 600mm Long	£11.52	£13.05	£18.95
BPG8280	Plastic Grab Rail – Rt. Angled 90° Dia. 35mm x 450 x 450mm	£31.18	£39.42	£42.51
BPG8282	Plastic Grab Rail – Rt. Angled 90° Dia. 35mm x 600x 600mm	£32.17	£41.38	£40.55
BPG8284	Plastic Grab Rail – Cranked 45° Dia. 35mm x 450 x 450mm	£29.36	£31.42	£32.55

Round, Injection Moulded ABS Rails for Interior use, with Ribbed Finish. 'Safeguarded' with Anti-bacterial infill. White available with or without Flange covers. Also available in Blue or Yellow with Flange covers only.

Budget Range

BPG7273	Plastic Grab Rail – Straight Dia. 35mm x 300mm Long	£7.55	N/A	N/A
BPG7275	Plastic Grab Rail – Straight Dia. 35mm x 450mm Long	£8.61	N/A	N/A
BPG7277	Plastic Grab Rail – Straight Dia. 35mm x 600mm Long	£9.96	N/A	N/A

Round, Injection Moulded ABS Rails for Interior use - Plain Finish. 'Safeguarded' with Anti-bacterial infill Available in White only - without Flange covers.

Exterior Use Round Section

Part No.	Description	Brown – With Covers
BPG9290BR	Plastic Grab Rail – Straight Dia. 35mm x 300mm Long	£11.33
BPG9291BR	Plastic Grab Rail – Straight Dia. 35mm x 450mm Long	£12.29
BPG9292BR	Plastic Grab Rail – Straight Dia. 35mm x 600mm Long	£13.67

Round, Injection Moulded ABS Rails for Exterior use UV Stabilised – with Ribbed Finish. Available in Brown Colour only, with Flange covers.

BPG8274

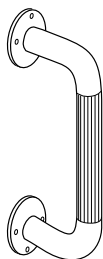

BPG8284

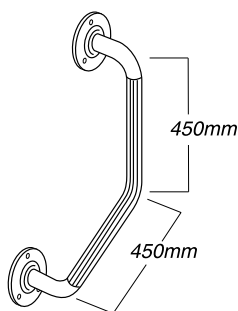

BPG7273

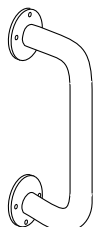

BPG9290BR

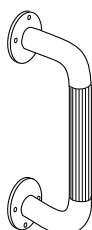

Accessories & Taps

Accessories

Part No.	Description	PCW
B573	Soap Dish	£6.79
B574	Towel Ring	£6.19
B575	Toilet Roll Holder	£7.40
B572	Tumbler and Toothbrush Holder	£6.19
B577	Toilet Roll Holder – Detachable for use with B301 Hinged Support Rails	£8.58
B578	Toilet Roll Holder – Detachable for use with B303/5 Hinged Support Rails	£8.58
B561	Towel Rail 300mm Long 450mm Long 600mm Long	£6.26 £7.16 £8.04

B573

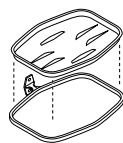

B574



B575

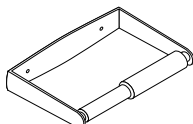

B572

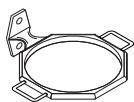

B577

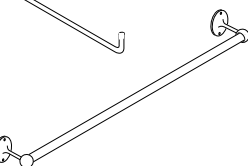

B561

Taps

A choice of Chrome Plated Lever Taps and Mixers with 1/4 turn ceramic discs for ease of use.

Luxury Range

With Multi Choice Levers

		CP
BPLBASTAP/L	Basin Taps	£36.00
BPLBHTAP/L	Bath Taps	£42.75
BPLMONTAP/L	Basin Monobloc	£61.95
BPLBTHFIL/L	Bath Filler	£67.50
BPLBTHSHW/L	Bath Shower Mixer with Shower Handset	£116.50



Budget Range

With 3" Levers

		CP
BPLBASTAP/B	Basin Taps	£21.40
BPLBHTAP/B	Bath Taps	£23.65
BPLMONTAP/B	Basin Monobloc	£58.50
BPLBTHFIL/B	Bath Filler	£52.00
BPLBTHSHW/B	Bath Shower Mixer with Shower Handset	£56.50



CARRIAGE CHARGES

Orders below £75 in value add £6 carriage. Orders between £75 and £200 add £12 carriage. Orders above £200 carriage paid. Overnight by request add £20.

Conditions of Sale

INTERPRETATION In these Conditions 'Buyer': means the person who accepts a quotation of the Seller for the sale of the Goods or whose order for the Goods is accepted by the Seller. 'Goods': means the Goods (including any installation of the Goods or any parts of them) which the Seller is to supply in accordance with these Conditions. 'Seller': means Barwood Products Limited. 'Conditions': Means the standards terms and conditions of sale set out in this document and (unless the context otherwise requires) includes any special terms and conditions agreed in writing between the Buyer and the Seller. 'Contract': means the Contract for the purchase and sale of the Goods. Any reference in these Conditions to any provision of a statute shall be construed as a reference to that provision as amended, re-enacted or extended at the relevant time. The headings in these Conditions are for convenience only and shall not affect their interpretation. All other words and expressions are to be given their normal English meaning taken in the context of the Contract.

BASIS OF THE SALE The Seller shall sell and the Buyer shall purchase the Goods in accordance with any written quotation of the Seller which is accepted by the Buyer, or any written order of the Buyer which is accepted by the Seller, subject to the exclusion of any other terms and conditions subject to which any such quotation is accepted or purported to be accepted, or any such order is made or purported to be made, by the Buyer. No conditions attached to endorsed upon or delivered with any document of the Buyer shall have effect in relation to the Contract. These terms and conditions can only be altered or qualified by a document signed by a director of the Seller setting out in full all the relevant alterations and qualifications. The Seller's employees or agents are not authorised to make any representations concerning the Goods unless confirmed by the Seller in writing. In entering into the Contract the Buyer acknowledges that it does not rely on, and waives any claim for breach of, any such representations which are not so confirmed. Acceptance of delivery of the Goods shall constitute acceptance of these Conditions where acceptance has not previously been communicated by the Buyer to the Seller.

1. ORDERS AND SPECIFICATIONS 1.1 No order submitted by the Buyer shall be deemed to be accepted by the Seller unless and until confirmed in writing by the Seller's authorised representative. 1.2 The quantity, quality and description of and any specification for the Goods shall be those set out in the Seller's quotation (if accepted by the Buyer) or the Buyer's order (if accepted by the Seller). 1.3 The Seller reserves the right to make any changes in the specification of the Goods which are required to conform with any applicable statutory or EC requirements, or which do not materially and detrimentally affect their quality or performance. 1.4 No order which has been accepted by the Seller may be cancelled by the Buyer except with the agreement in writing of the Seller and on terms that the Buyer shall indemnify the Seller in full against all loss (including loss of profit), costs (including the cost of all labour and materials used), damages, charges, and expenses incurred by the Seller as a result of the cancellation.

2. PRICE OF THE GOODS 2.1 The price of the Goods shall be the Seller's quoted price or where no price has been quoted (or a quoted price is no longer valid), the price listed in the Seller's published price list current at the date of acceptance of the order. All prices quoted are valid for 14 days only or until earlier acceptance by the Buyer, after which time they may be altered by the Seller without giving notice to the Buyer. 2.2 The Seller reserves the right by giving notice to the Buyer at any time before delivery to increase the price of the Goods to reflect any increase in the cost to the Seller which is due to any factor beyond the control of the Seller (such as, without limitation, any foreign exchange fluctuation, currency regulation, alteration of duties, increase in the costs of labour, materials or other costs of manufacture), any change in delivery dates, quantities or specifications for the Goods which is requested by the Buyer, or any delay caused by any instructions of the Buyer or failure of the Buyer to give the Seller adequate information or instructions. 2.3 Except as otherwise stated under the terms of any quotation or in any price list of the Seller, and unless otherwise agreed in writing between the Buyer and the Seller, all prices are given by the Seller on an ex works basis, and where the Seller agrees to deliver the Goods otherwise than at the Seller's premises, the Buyer shall be liable to pay the Seller's charges for transport, packaging and insurance. No refunds are payable for return of packaging. 2.4 The price is exclusive of any applicable Value Added Tax, which the Buyer shall be additionally liable to pay to the Seller. 2.5 The cost of carriage and packaging if required by the Buyer shall unless otherwise agreed by the Seller in writing, be charged extra.

3. TERMS OF PAYMENT 3.1 Subject to any special terms agreed in writing by the Buyer and the Seller the Seller shall be entitled to invoice the Buyer for the price of the Goods on or at any time after delivery of the Goods unless the Goods are to be collected by the Buyer or the Buyer wrongfully fails to take delivery of the Goods in which event the Seller shall be entitled to invoice the Buyer for the price at any time after the Seller has notified the Buyer that the Goods are ready for collection or (as the case may be) the Seller has tendered delivery of the Goods. 3.2 The Buyer shall pay the price of the Goods by the last day of the month following the month of invoice, notwithstanding that delivery may not have taken place and the property of the Goods has not passed to the Buyer. The time of payment of the price shall be of the essence of the contract. Receipts for payment will be issued only upon request. 3.3 Where the Goods are delivered by installments the Seller may invoice each installment separately and the Buyer shall pay such invoices in accordance with these conditions. 3.4 If the Buyer fails to make any payment on the due date then, without prejudice to any other right or remedy available to the Seller, the Seller shall be entitled to: 3.4.1 cancel the contract or suspend any further deliveries or performance to the Buyer; 3.4.2 appropriate any payment made by the Buyer to such of the Goods (or the goods supplied under any other contract between the Buyer and the Seller) as the Seller may think fit (notwithstanding any purported appropriation by the Buyer); and 3.4.3 charge the Buyer interest (both before and after any judgement) on the amount unpaid, at the rate of 4 per cent per annum above Barclays Bank PLC base rate from time to time, until payment in full is made (a part of a month being treated as a full month for the purpose of calculating interest). 3.5 No disputes arising under the Contract and no delays beyond the control of the Seller shall interfere with the prompt payment in full by the Buyer. 3.6 The Buyer shall reimburse the Seller any legal and other costs incurred by the Seller in enforcing the terms of the Contract, such reimbursement to be on a full indemnity basis.

4. DELIVERY 4.1 Delivery of the Goods shall be made by the Buyer collecting the Goods at the Seller's premises at any time after the Seller has notified the Buyer that the Goods are ready for collection or, if some other place for delivery is agreed by the Seller, by the Seller delivering the Goods to that place. 4.2 Any dates quoted for delivery of the Goods are approximate only and the Seller shall not be liable for any delay in delivery of the Goods howsoever caused. Time for delivery or performance shall not be of the essence unless previously agreed by the Seller in writing. The Goods may be delivered by the Seller in advance of the quoted date upon giving reasonable notice to the Buyer. 4.3 Where the Goods are to be delivered in installments each delivery shall continue a separate contract and failure by the Seller to deliver any one or more of the installments in accordance with these conditions or any claim by the Buyer in respect of any one or more installments shall not entitle the Buyer to treat the Contract as a whole as repudiated. 4.4 The Seller will endeavour to comply with reasonable requests by the Buyer for postponement of delivery but shall be under no obligation to do so. Where delivery is postponed at the Buyer's request the Buyer shall pay all costs and expenses (including storage, insurance and transportation) occasioned thereby. 4.5 If the Buyer refuses or fails to take delivery of the Goods or refuses or fails to give the Seller adequate delivery instructions at the time stated for delivery (otherwise than by reason of any cause beyond the Buyer's reasonable control or by reason of the Seller's fault) then, without prejudice to any other right or remedy available to the Seller, the Seller may: 4.5.1 store the Goods until actual delivery and charge the Buyer for the reasonable costs (including insurance) of storage; or 4.5.2 sell the Goods at the best price readily obtainable and (after deducting all reasonable storage and selling expenses) account to the Buyer for the excess over the price under the Contract or charge the Buyer for any shortfall below the price under the Contract. 4.6 Unless otherwise expressly agreed in writing by the Seller any packaging supplied by the Seller is intended to be only sufficient to protect the Goods for all normal conditions of transit and for the normal period of transit only.

5. DEFECTS 5.1 The Buyer shall have no right or claim for shortages or defects apparent on visual inspection unless: 5.1.1 The Buyer inspects the Goods immediately on arrival at its premises or other agreed destination and 5.1.2 A written complaint is made to the Seller within 7 days of receipt of the Goods or such shorter period as the carriers conditions (if applicable) require specifying the shortage or defect and

5.1.3 the Seller is given an opportunity to inspect the Goods and investigate any complaint before any use is made of the Goods. If a complaint is not made to the Seller as herein provided or the Goods shall be deemed to be in all respects in accordance with the contract and the Buyer shall be bound to pay for the same accordingly. 5.2 Whether or not the Seller arranges delivery the Seller is in no way responsible for the delivery of the Goods and is in no way liable for claims for loss or damage in transit which must be made by the Buyer against the Carrier in accordance with the Carrier's conditions. 5.3 All allegations as to total non-delivery of any consignment of the Goods must be made by the Buyer in writing to the Carrier and to the Seller within 10 days of the date of the Seller's advice note or invoice or other notification of despatch, or within such shorter time limit as may be specified in any conditions of the Carrier. 5.4 Failure by the Buyer to comply with the provisions hereof shall render the Buyer liable for any temporary or permanent loss of the Goods and all additional costs and expenses of the Seller in relation thereto. 5.5 The Buyer shall have no claim in respect of defects not apparent on visual inspection at the time of delivery unless: i) a written complaint is sent to the Seller as soon as reasonably practicable after the defect is noticed and no use is made of the Goods thereafter and no alteration made thereto by the Buyer before the Seller is given the opportunity in accordance with sub-paragraph 5.6 of this condition to inspect the Goods; and ii) the complaint is sent within 1 month of the date of delivery by the Seller. 5.6 The Seller may within 30 days of receiving such a written complaint inspect the Goods and the Buyer if so required by the Seller shall take all steps necessary to enable the Seller to do so.

6. RISK AND PROPERTY 6.1 Risk shall pass to the Buyer so that the Buyer is responsible for all loss damage or deterioration to the Goods. 6.1.1 in the case of Goods to be delivered at the Seller's premises; when the Seller notifies the Buyer that the Goods are available for collection; or 6.1.2 in the case of Goods to be delivered otherwise than at the Seller's premises when the Goods or a relevant part thereof leave the premises of the Seller whether or not the Seller arranges transport and where the Goods are delivered by carrier any claims for loss or damage in transit must be made by the Buyer against the carrier in accordance with the carrier's conditions. 6.2 Notwithstanding delivery and the passing of risk in the Goods, or any other provision of these Conditions, the property in the Goods shall not pass to the Buyer until the Seller has received in cash or cleared funds payment in full of the price of the Goods and all other Goods agreed to be sold by the Seller to the Buyer for which payment is then due. 6.3 Until such time as the property in the Goods passes to the Buyer, the Buyer shall hold the Goods as the Seller's fiduciary agent and bailee and shall keep the Goods separate from those of the Buyer and third parties and properly stored, protected and insured and identified as the Seller's property. 6.4 Until such time as the property in the Goods passes to the Buyer (and provided the Goods are still in existence and have not been resold), the Seller shall be entitled at any time to require the Buyer to deliver up the Goods to the Seller and, if the Buyer fails to do so forthwith, to enter upon any premises of the Buyer or any third party where the Goods are stored and repossess the Goods. 6.5 The Buyer shall not be entitled to pledge or in any way charge by way of security for any indebtedness any of the Goods which remain the property of the Seller shall (without prejudice to any other right or remedy of the Seller) forthwith become due and payable.

7. WARRANTIES AND LIABILITY 7.1 Subject to the conditions set out below the Seller solely and exclusively warrants that unless otherwise specifically agreed in writing Goods supplied by the Seller will correspond with their specification and will be free from defects in material and workmanship at the time of delivery. 7.2 The above warranty is given by the Seller subject to the following conditions: 7.2.1 the Seller shall be under no liability in respect of any defect arising from fair wear and tear, willful damage, negligence, abnormal working conditions, misuse or alteration or repair of the Goods without the Seller's approval or replacement parts which are not in accordance with the original specification. 7.2.2 The Seller shall be under no liability under the above warranty (or any other warranty, condition or guarantee) if the total price for the Goods has not been paid by the due date for payment. 7.3 Subject as expressly provided in these Conditions, all warranties, conditions or other terms implied by statute or common law are excluded to the fullest extent permitted by law. 7.4 Where any valid claim in respect of any of the Goods which is based on any defect in the quality or condition of the Goods or their failure to meet specification is notified to the Seller in accordance with these Conditions, the Seller shall be entitled at its option to replace the Goods (or the part in question) or make good the defect in the Goods or, at the Seller's sole discretion, refund the Buyer the price of the Goods (or a proportionate part of the price), the Seller shall have no further liability to the Buyer PROVIDED THAT: 7.4.1 the defective Goods shall be returned carriage paid to the Seller whereupon they shall become the property of the Seller; 7.4.2 in the event that the Buyer requests the Seller's personnel to attend at its premises to repair or replace the Goods, the Seller shall be entitled to charge for travelling and labour at its prevailing standard rates. 7.5 Any warranty by the Seller is intended solely for the benefit of the Buyer. All claims hereunder must be made by the Buyer and not by any other person, firm or company who may have possession of the Goods. 7.6 Except in respect of death or personal injury caused by the Seller's negligence, the Seller shall not be liable to the Buyer by reason of any representation or any implied warranty, condition or other term, or any duty at common law, or under the express terms of the Contract, for any consequential loss or damage (whether for loss of profit or otherwise), costs, expenses or other claims for consequential compensation whatsoever (and whether caused by negligence of the Seller, its employees or agents or otherwise) which arise out of or in connection with the supply of the Goods or their use or resale by the Buyer except as expressly provided in these Conditions. 7.7 The Seller shall not be liable to the Buyer or be deemed to be in breach of the Contract by reason of any delay in performing or any failure to perform any of the Seller's obligations in relation to Goods or Services, if the delay or failure was due to any cause beyond the Seller's reasonable control including in particular: 7.7.1 act of God, explosion, flood, tempest, fire or accident. 7.7.2 war or threat of war, sabotage, insurrection, civil disturbance, or requisition; 7.7.3 acts, restrictions, regulations, bye-laws, prohibitions, or measures of any kind on the part of any governmental, parliamentary or local authority; 7.7.4 import or export regulations or embargoes; 7.7.5 strikes, lock-outs, or other industrial actions or trade disputes (whether involving employees of the Seller or of a third party); 7.7.6 difficulties in obtaining raw materials, labour, fuel, parts or machinery; 7.7.7 power failure or breakdown in machinery. 7.8 The Seller does not warrant the fitness or suitability of any Goods supplied for any purpose or application and the implied warranties and conditions contained in section 13, 14 and 15 of the Sale of Goods Act 1979 (as amended by the Sale and Supply of Goods Act 1994) and any other conditions or warranties implied by trade custom or usage are hereby expressly excluded. 7.9 The Buyer agrees that apart from the express terms contained herein or in the quotation or in any document expressly stipulated therein to form part of the Contract and to be outside the provisions of this condition no statement or representation has been made by the Seller relating to the Goods supplied or if any such statement or representation has been made the Buyer warrants that he understood it to be a statement of opinion only and did not rely on it.

8. INSOLVENCY OF BUYER 8.1 This clause applies if: 8.1.1 the Buyer makes any voluntary arrangement with its creditors or becomes subject to an administration order or (being an individual or firm) becomes bankrupt or (being a company) goes into liquidation (otherwise than for the purposes of amalgamation or reconstruction); or 8.1.2 an encumbrancer takes possession or a receiver is appointed of any of the property or assets of the Buyer; or 8.1.3 the Buyer ceases, or threatens to cease, to carry on business; or 8.1.4 the Seller reasonably apprehends that any of the events mentioned above is about to occur in relation to the Buyer and notifies the Buyer accordingly. 8.2 Without prejudice to any other right or remedy available to the Seller if this condition applies the Seller shall be entitled to cancel the Contract or suspend any further deliveries under the Contract without any liability to the Buyer and, if the Goods have been delivered but not paid for, the price shall become immediately due and payable notwithstanding any previous agreement or arrangement to the contrary.

9. OWNERSHIP AND RETENTION OF TITLE Equitable and beneficial ownership of any goods supplied will remain with the Seller until all monies outstanding are paid in full by the Buyer although risk will pass to the Buyer upon delivery of the Goods. The Buyer will undertake to properly store and insure the Goods and have them identified as the Buyer's property. In the event of default of payment on the due date the Seller will be entitled to repossess any Goods which remain its property. The Buyer shall afford access at such times as required by the Seller to any premises occupied by the Buyer where the Goods might be situated.



BARWOOD PRODUCTS LIMITED

Central Works, Curzon Street, Burton upon Trent, Staffs DE14 2DH

Tel: 01283 516526 Fax: 01283 517597 www.barwoodproducts.com

Prices correct at time of going to press. Barwood Products Ltd reserve the right to change products, specifications and prices without prior notice. All photographs/line drawings are for guidance only. E & O E